

C E S A R

WILLIAMSBURG OUTDOOR

Workstation

Design by García Cumini

Williamsburg is a counter, a workstation which combines structural strength with aesthetic simplicity. The combination of durability and simplicity is among the primary and distinctive characteristics of Williamsburg, inspired by the industrial world, yet at the same time able to find its way towards more domestic environments: the structure, in fact, calls to mind the architectural image of a modern bridge, a source of inspiration for designers thanks to the presence of solid lateral pilasters connected by a longitudinal element.

CONCEPT

Williamsburg is a workstation. A functional surface made up of two or three lateral supports and a worktop which can be used for the essential activities of cooking, preparation, and washing.

With no bulk beneath the countertop, the structure encourages socialising and sharing, the perfect combination of table, snack counter and traditional kitchen island.



cesar.it

©Cesar Arredamenti Spa

WILLIAMSBURG OUTDOOR

Workstation

Design by García Cumini

STRUCTURAL ELEMENTS

Williamsburg earns itself a place outdoors by offering a large surface to prepare food and to share it in the open air. Made entirely of AISI 316 stainless steel, Williamsburg outdoor was developed in partnership with the Foster brand.

In its simpler version, the Williamsburg workstation is made up of two elements: two large legs and a worktop. The worktop can be equipped with a cook top, a sink with drain, accessories like side bottle racks, and an additional worktop for more space.

ACCESSORIES

Bottle-rack

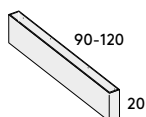

Casing to conceal the underside of a sink or hob

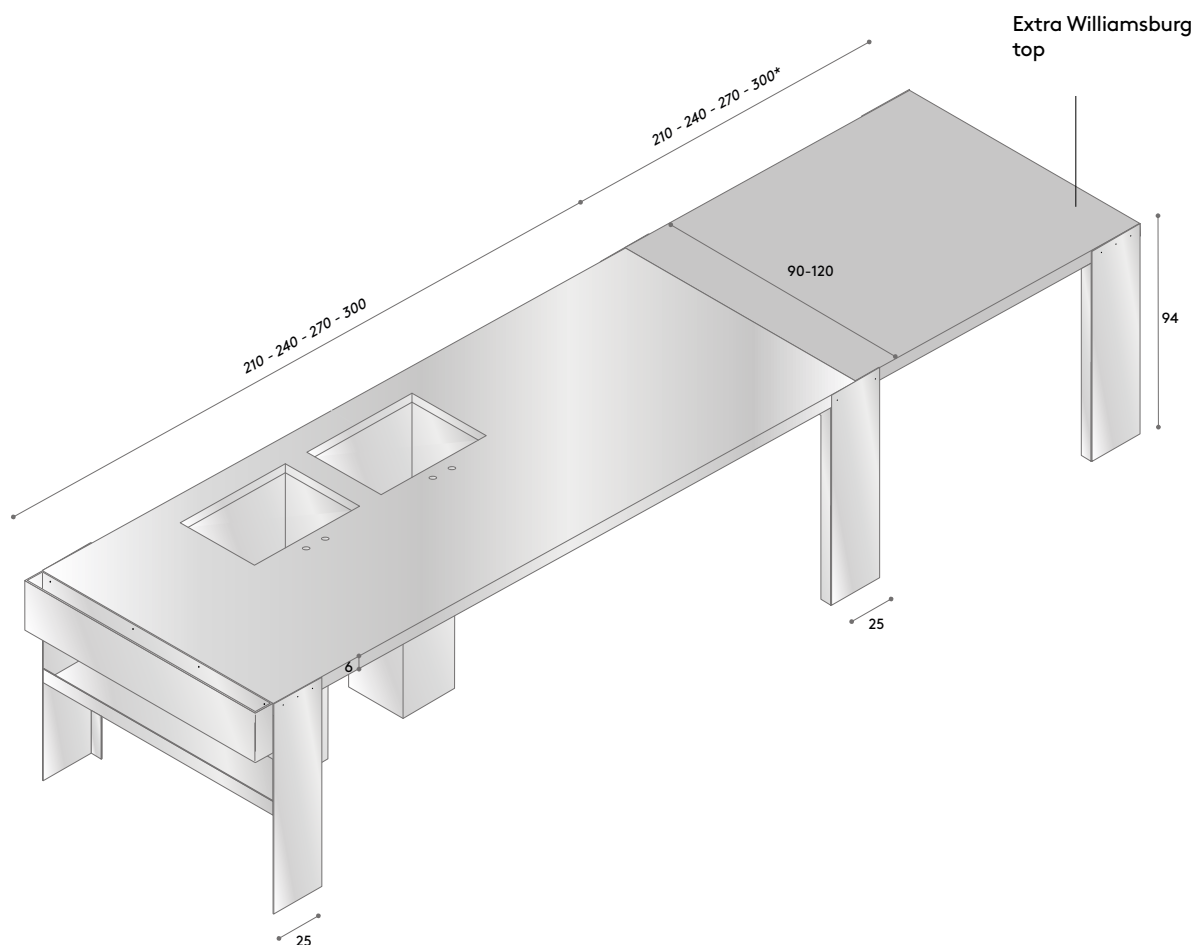
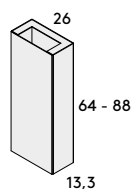

CUPBOARD WILLIAMSBURG

Outdoor cabinetry

Design by García Cumini

➤ The diamond-like effect of the cupboard recalls the look of large industrial doors and therefore the way in which Williamsburg draws inspiration from that part of the industrial world which has found its way into more domestic and residential environments. Like the Williamsburg workstation, the cupboards represent a flexible element that creates a bridge between the inside and the outside of a space, allowing these to communicate with one another.

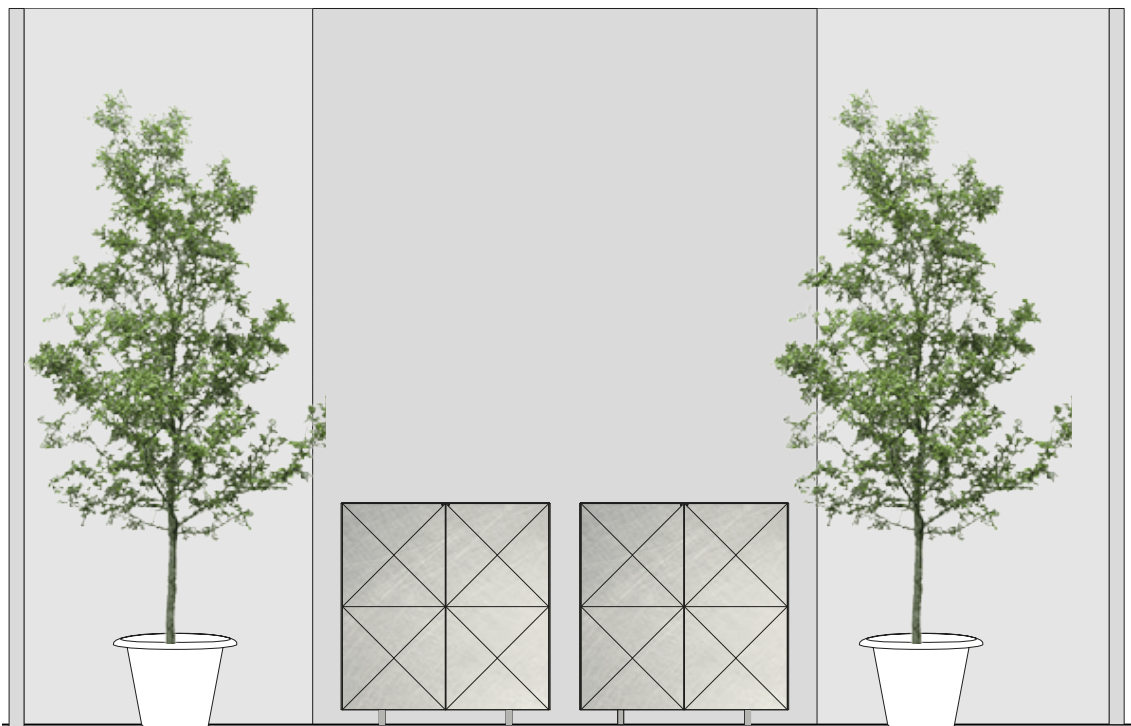
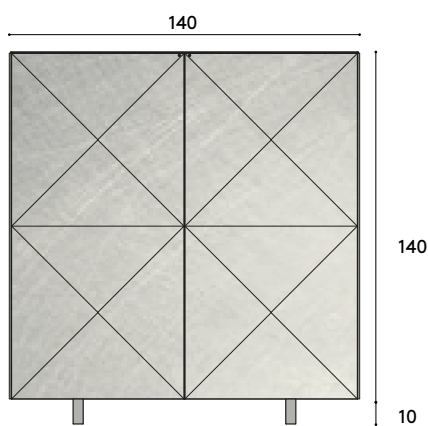

CUPBOARD WILLIAMSBURG

Outdoor cabinetry

Design by García Cumini

GENERAL INFORMATION

The shelves are available in AISI 316 stainless steel or ceramic.

The drawer runners and feet are made of AISI 316 stainless steel.

The hinges and runners don't have soft closing and/or push-pull mechanisms.

! It is mandatory to fix the cupboard to the wall.

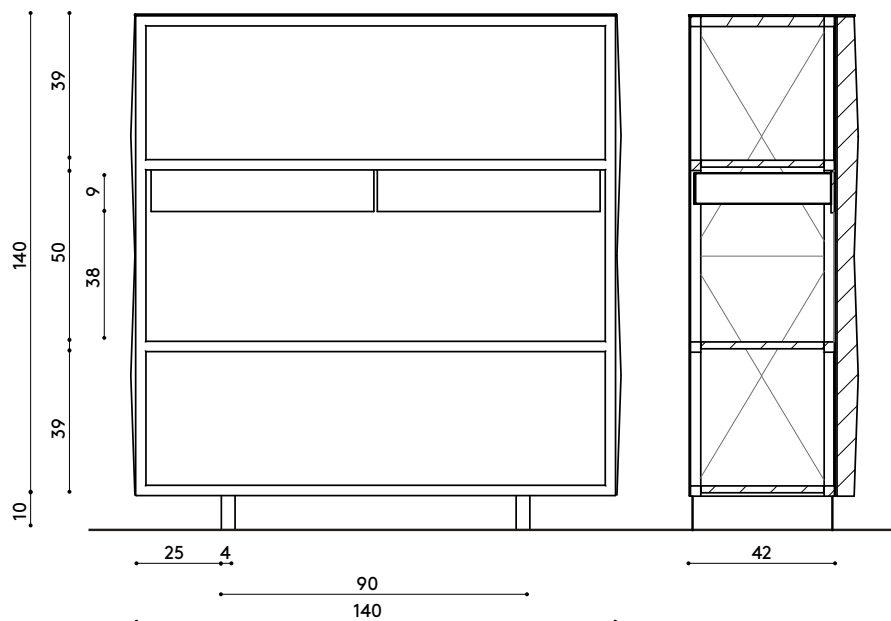

FINISHES

STAINLESS STEEL



AISI 316 Vintage

KNOB



Polished Nickel

WILLIAMSBURG OUTDOOR

Workstation

Design by García Cumini

FINISHES

STAINLESS STEEL



AISI 316 Vintage

| Worktop | Legs | Extratop |
|---------|------|----------|
| ✓ | ✓ | ✓ |

WORKTOP FINISHES

INALCO CERAMICS

This material is made from extremely pure minerals melted at a high temperature which gives it excellent technical, surface and aesthetic properties. Moreover, the full digital technology applied to the whole production process allows the decorative design to be totally controlled so as to ensure aesthetic continuity throughout the product's core and on its surface. Ceramic guarantees excellent hygiene (it is stain resistant, non-absorbent and resistant to chemicals) as well as resistance to impact, scratches and thermal shock.

| Worktop | Legs | Extratop |
|---------|------|----------|
| ✓ | ✗ | ✓ |

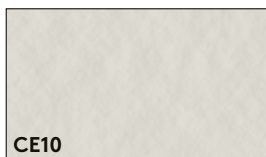

CE10
Blanco Abujardado Silk



CE12
Blanco Natural Silk

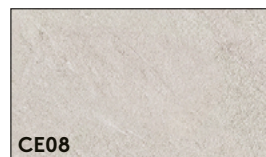

CE08
Blanco Plus Abujardado Pacific

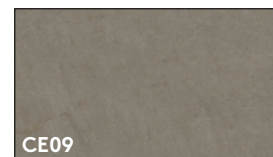

CE09
Moka Abujardado Jasper

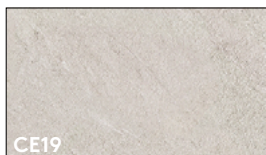

CE19
Pacific Gris Abujardado



CE13
Gris Abujardado Geo

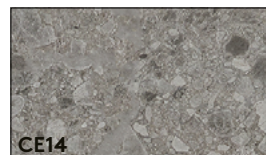

CE14
Gris Abujardado Iseo



CE15
Gris Natural Senda

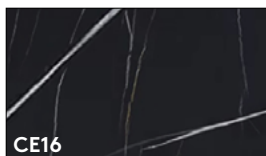

CE16
Negro Natural Azalai

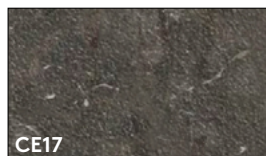

CE17
Marron Abujardado Umbra

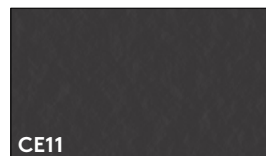

CE11
Negro Abujardado Silk

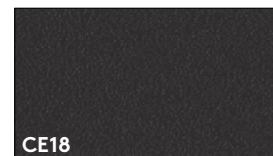

CE18
Negro Natural Silk

WILLIAMSBURG OUTDOOR

Workstation

Design by García Cumini

WORKTOP FINISHES

DEKTON

| Worktop | Legs | Extratop |
|---------|------|----------|
| ✓ | ✗ | ✓ |

Dekton benefits from sinterized particle technology, a hi-tech process that reproduces the changes natural stone is subjected to when it undergoes the effect of high temperatures and pressures over thousands of years. An electronic microscope allows us to fully appreciate the total lack of porosity of this material as well as the absence of micro defects that can cause stress or weak spots. Dekton is very resistant to UV rays, stains, scratches and thermal shocks and doesn't become discoloured or lose its depth of colour over time.

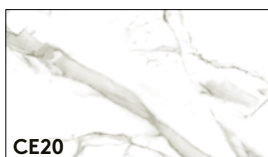

CE20

Aura

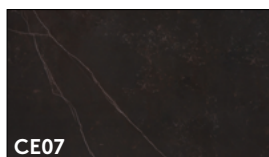

CE07

Kelya



CE22

Creta

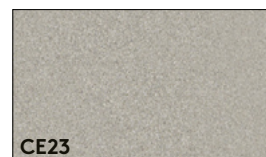

CE23

Sirocco

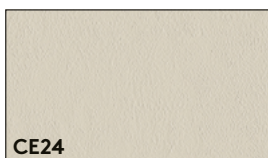

CE24

Edora

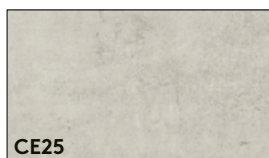

CE25

Lunar

ENGINEERED STONE

| Worktop | Legs | Extratop |
|---------|------|----------|
| ✓ | ✗ | ✓ |

This material uses technology to reinvent the natural beauty of marble. It's an engineered material made up of about 95% natural crushed stone (marble) and 5% binding resins. A sophisticated blending process produces a product as homogenous as natural stone. Advantages: the constant quality you can expect from an industrial product – homogeneous structure and colours – the beauty and appearance of natural stone – practical to look after.



PN24

Bianco Apuano

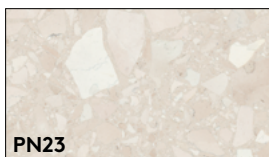

PN23

Rosa Perlino

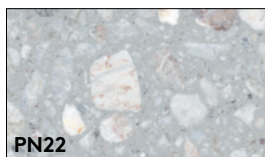

PN22

Fior Di Pesco

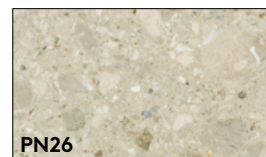

PN26

Breccia Andorra

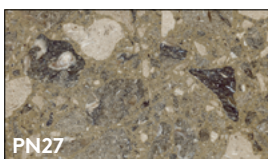

PN27

Tobago

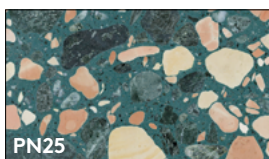

PN25

Palladio Fenice

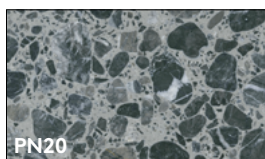

PN20

Palladio Laguna



PN26

Nero Portorò

WILLIAMSBURG OUTDOOR

Workstation

Design by García Cumini

WORKTOP FINISHES

| Worktop | Gamboni | Extratop |
|---------|---------|----------|
| ✔ | ✘ | ✔ |

NATURAL STONES

Marble, stone and composite products are unique items that cannot be reproduced because they are the beautiful result of a natural process. These are natural elements extracted from quarries and then processed by man. They don't usually have an even finish; their veins are irregular and colours dissimilar and they may present surface veins that look like cracks as well as impurities and fossils. After having selected the slabs, while still on the quarry site, the skilful hands of artisans fill in any holes with special resins, almost turning each slab into a work of art. Without this work none of the stone slabs would be solid enough to be used in your home. These distinctive features are essential to the uniqueness, refinement and natural properties of this material. Marble, stone, granite and composite are not very resistant to acids, not even to weak ones such as those contained in lemons, coffee, vinegar and the like. If the surface is porous, it may absorb liquids.



PN01
Marmo Bianco Carrara

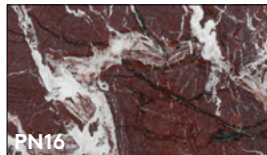

PN16
Marmo Rosso Lepanto

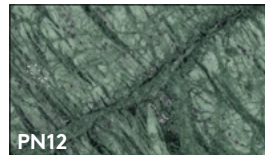

PN12
Marmo Verde Guatemala

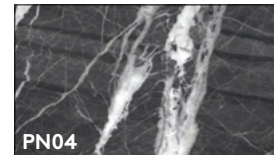

PN04
Marmo Grey Saint Laurent

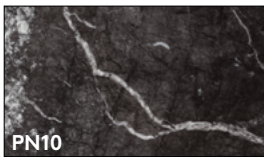

PN10
Marmo Grigio Carnico

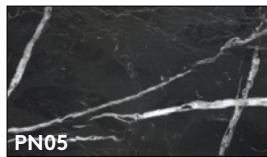

PN05
Marmo Nero Marquina

NEW FINISH 2022

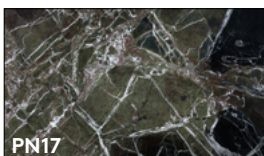

PN17
Breccia Imperiale

A precious and natural anomaly that features a web of white veining on a background that ranges from dark to light green, in a way recalling the vivid tones of the forest's lush undergrowth.